

14 Ø22 BOLTING DOWN HOLES

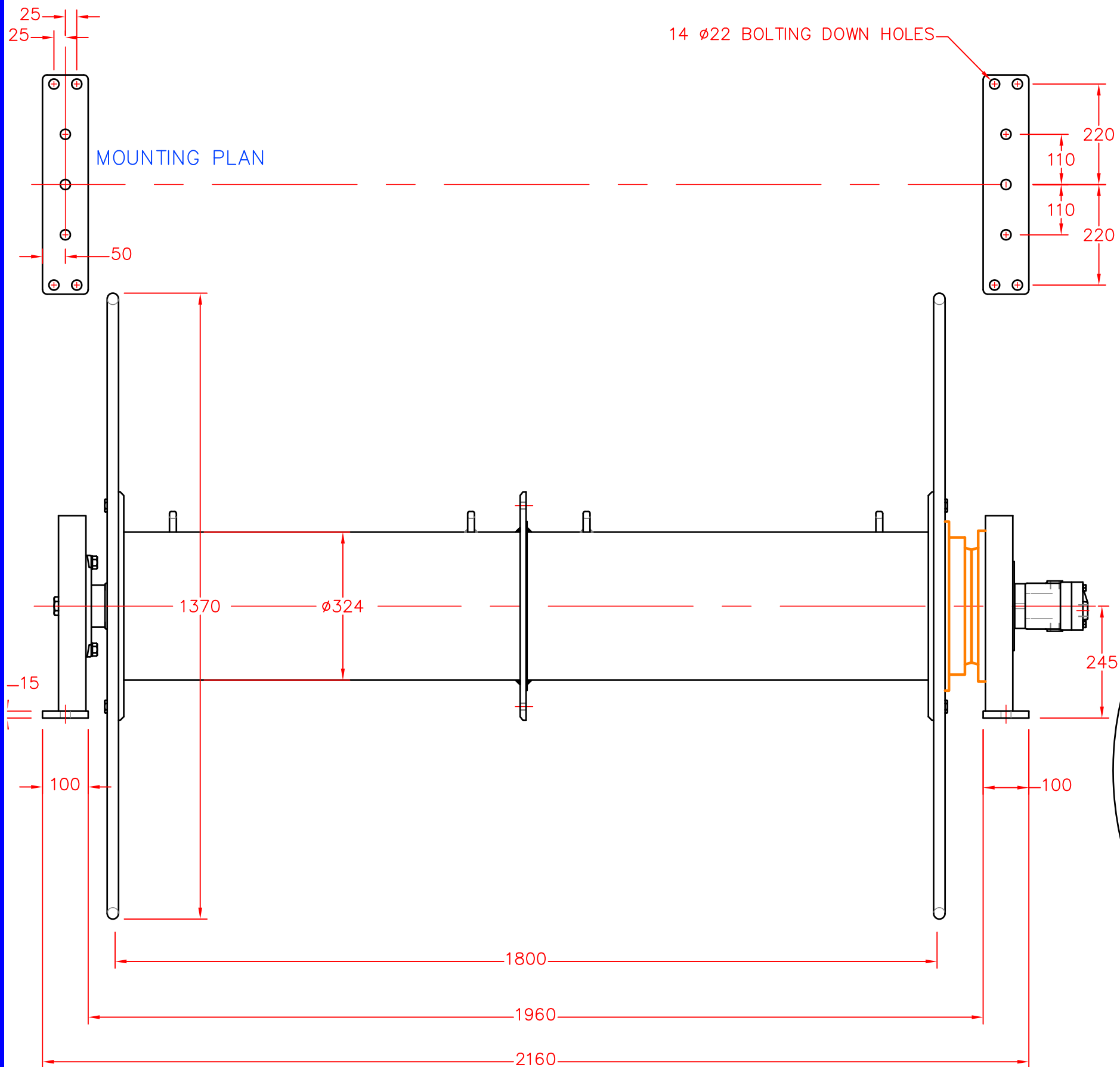

**NET DRUM INCORPORATES: -**  
 PLANETARY REDUCTION GEARBOX  
 WITH FAIL SAFE MULTI DISC BRAKE, HYDRAULIC.  
 MOTOR AND MOTION CONTROL VALVE.  
 GEARBOX REDUCTION \_\_\_\_\_ 66:1  
 MOTOR CAPACITY \_\_\_\_\_ 30CC/rev.

**HYDRAULIC REQUIREMENTS: -**  
 FLOW RATE REQUIRED \_\_\_\_\_ 78 L.P.M.  
 WORKING PRESSURE \_\_\_\_\_ 150 BAR

**PERFORMANCE OF NET DRUM: -**  
 DRUM WILL ROTATE AT UP TO 37 R.P.M.  
 FIRST LAYER PULL (ON Ø324) \_\_\_\_\_ 2500 KG.  
 PULL ON Ø500 \_\_\_\_\_ 1600 KG.

CALCULATED WEIGHT - 500Kg APPROX.

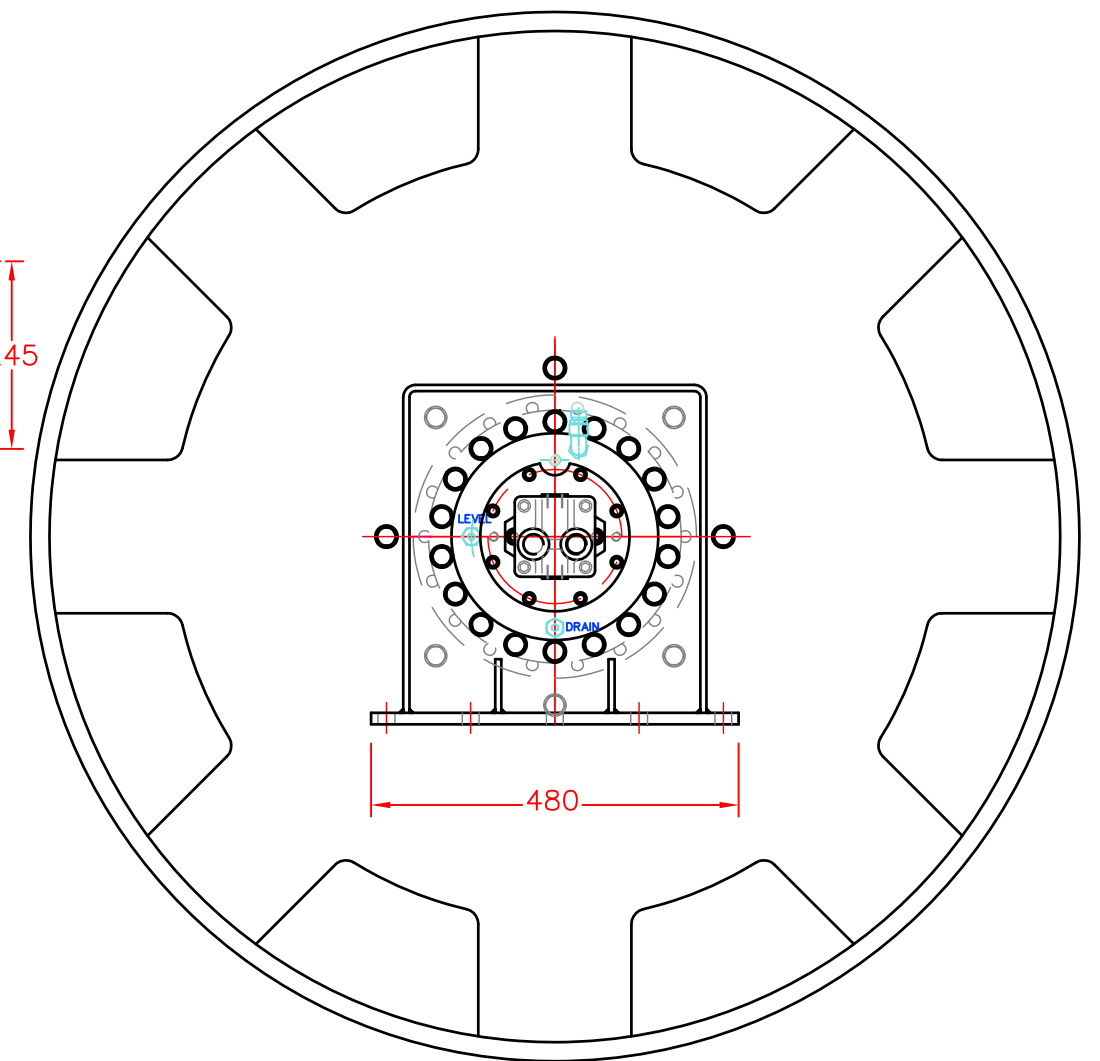

FOR TOM McCLURE - NEWLYN JOB No. 44285

ALTERATIONS	DATE	ALTERATIONS	DATE
(A) FINAL DRAWING FOR APPROVAL	22.10.07		
(B) CENTRE FLANGE ADDED	28.05.08		
		SCALE	1:10
		DRN.	A.M.
		DATE	22.05.08



TITLE	
2.5 TON SINGLE DRUM NET DRUM	
SPENCER CARTER LTD. FALMOUTH, CORNWALL, U.K.	DRG.NO.
TEL. (01326) 373423 FAX. (01326) 373571	623-799