

A LINK AND PIN ARE PROVIDED FOR STOWING THE JIB IN A POSITION 90° FROM CENTRE, ON THIS SIDE OF THE PEDESTAL.

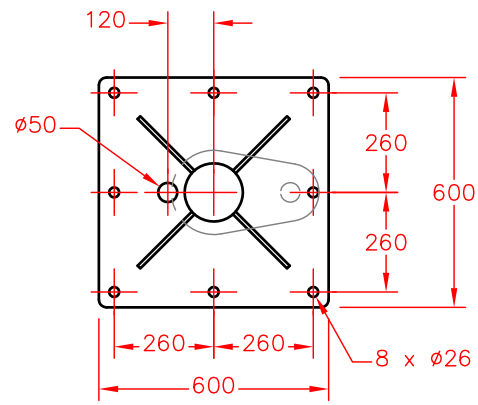
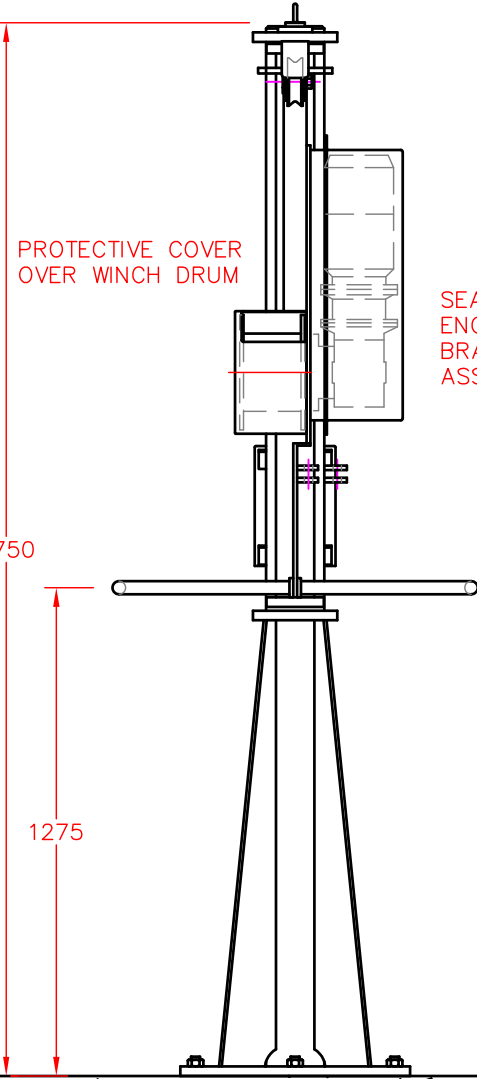
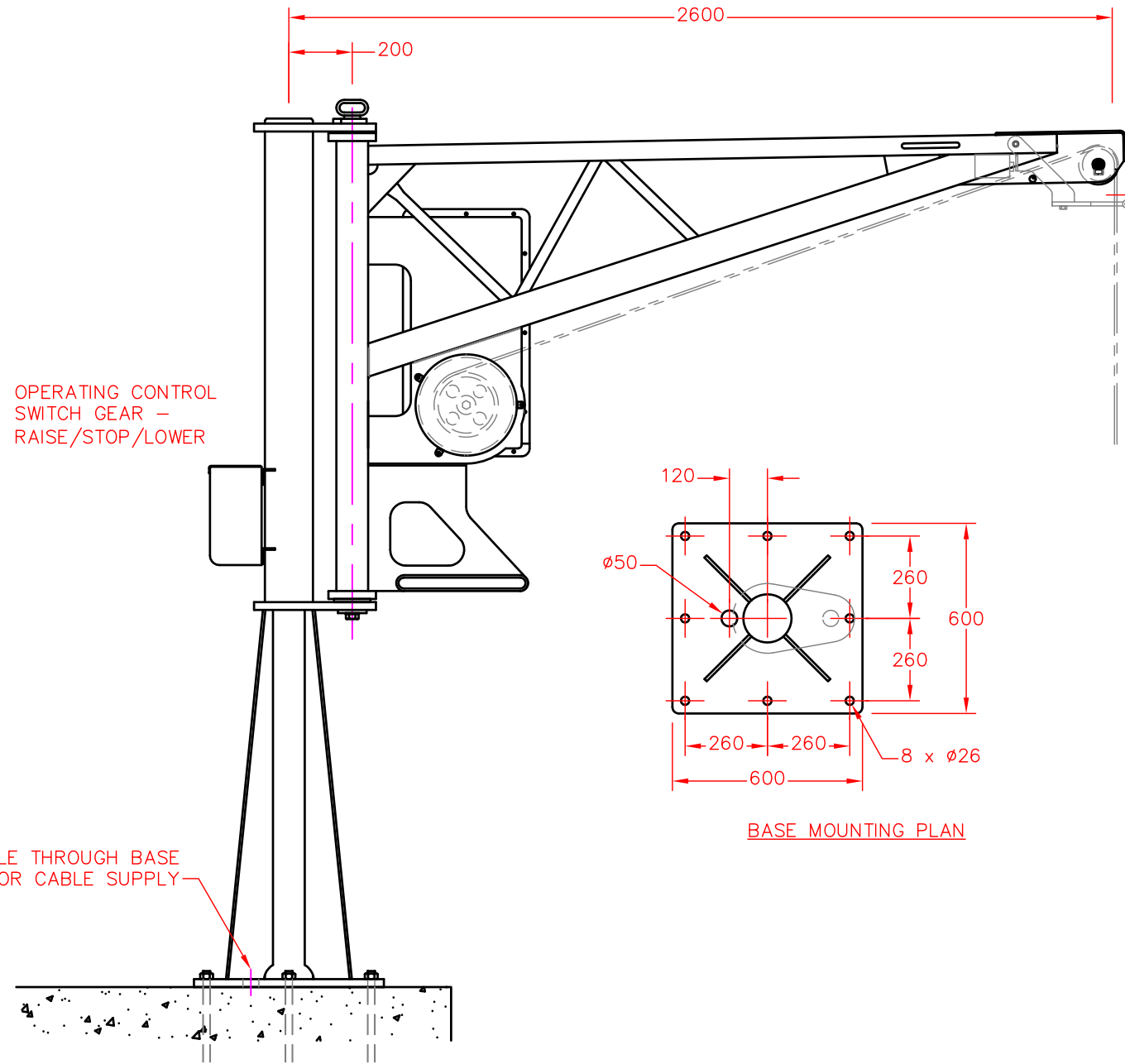
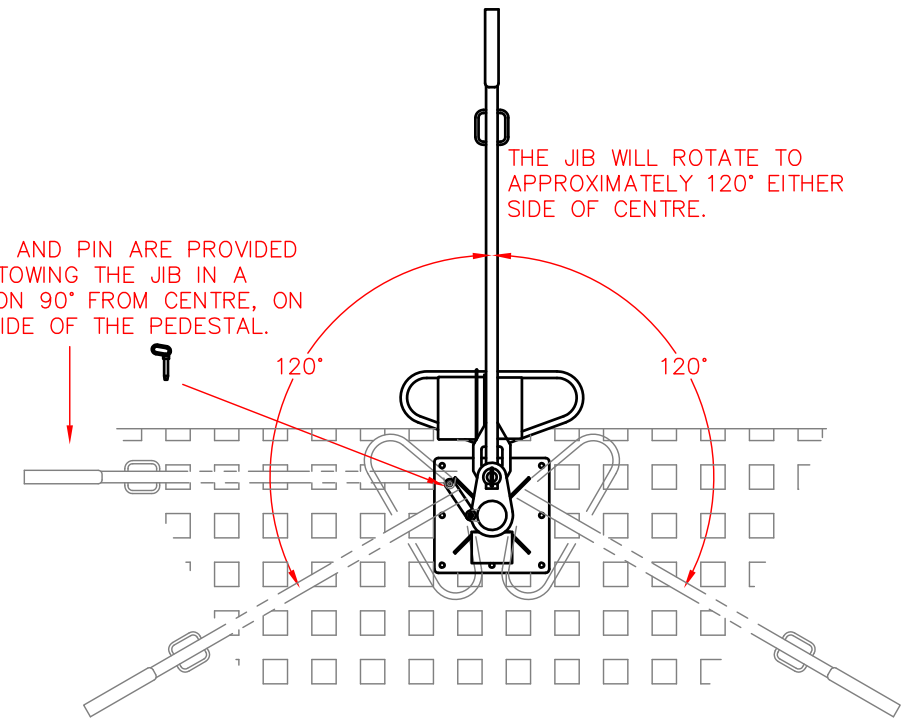

BASE MOUNTING PLAN

200 KG. UNLOADING WINCH AND DAVIT.

SUITABLE FOR QUAYSIDE INSTALLATION FOR THE LIFTING OF FISH BOXES FROM VESSEL TO SHORE.

DESIGNED FOR THE MARINE ENVIRONMENT WITH AN ALL WELDED STEEL CONSTRUCTION, FINISHED GALVANISED, WITH A TOTALLY ENCLOSED COMPARTMENT FOR THE ELECTRIC MOTOR, FAILSAFE BRAKE AND GEARBOX AND WITH SEALED WINCH DRUM BEARINGS. OPTIONAL ADDITIONS INCLUDE AN OVER-TRAVEL TRIP SWITCH MECHANISM.

- WORKING LIFT \_\_\_\_\_ 200 Kg.
- MAXIMUM LIFT \_\_\_\_\_ 250 Kg.
- WIRE SPEED \_\_\_\_\_ 20 M/Min.
- WIRE CAPACITY \_\_\_\_\_ 14 METERS X 8MM WIRE
- MOTOR SIZE \_\_\_\_\_ 1.5 Kw. 3Ph.
- WEIGHT \_\_\_\_\_ 600 Kg.

SUPPLY REQUIRED \_\_\_\_\_ THREE PHASE AND NEUTRAL

ALTERATIONS	DATE	ALTERATIONS	DATE
		NOTE OF SUPPLY-3PH + NEUTRAL INCLUDED	02.06.05

SCALE	1: 20
DRN.	M.J.S.
DATE	20.09.01

SCALE	1: 20
DRN.	M.J.S.
DATE	20.09.01



TITLE UNLOADING WINCH AND DAVIT	
SPENCER CARTER LTD. FALMOUTH, CORNWALL, U.K.	DRG.NO. 623-606
TEL. (01326) 373423 FAX. (01326) 373571	