

HYDRAULIC SUPPLY REQUIRED \_\_\_\_\_ 37 LPM. @ 140 BAR  
 THIS WILL BE AVAILABLE WITH PUMP SIZE 2P8 AND AN ENGINE  
 SPEED OF 1000 RPM.

WINCH SPEED \_\_\_\_\_ 70 RPM  
 WINCH TORQUE \_\_\_\_\_ 800 NM

FIRST LAYER WIRE SPEED \_\_\_\_\_ 18 METRES/MINUTE  
 MID LAYER WIRE SPEED \_\_\_\_\_ 40 METRES/MINUTE  
 TOP LAYER WIRE SPEED \_\_\_\_\_ 65 METRES/MINUTE

WINCH PULL FIRST LAYER \_\_\_\_\_ 2.14 TONS  
 MID LAYER \_\_\_\_\_ 0.69 TONS  
 TOP LAYER \_\_\_\_\_ 0.5 TONS

WIRE CAPACITY TO MID LAYER \_\_\_\_\_ 180M X 8 MM WIRE  
 TO TOP LAYER \_\_\_\_\_ 360M X 8 MM WIRE

THE TOP LAYER IS CALCULATED TO HAVE FILLED THE WINCH  
 DRUM TO Ø320.

WIEGHT.....250 KG.

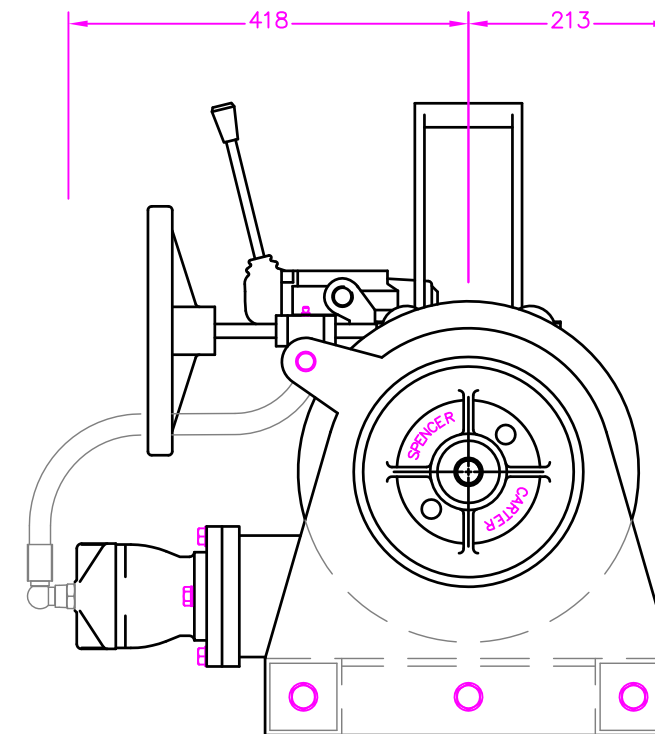
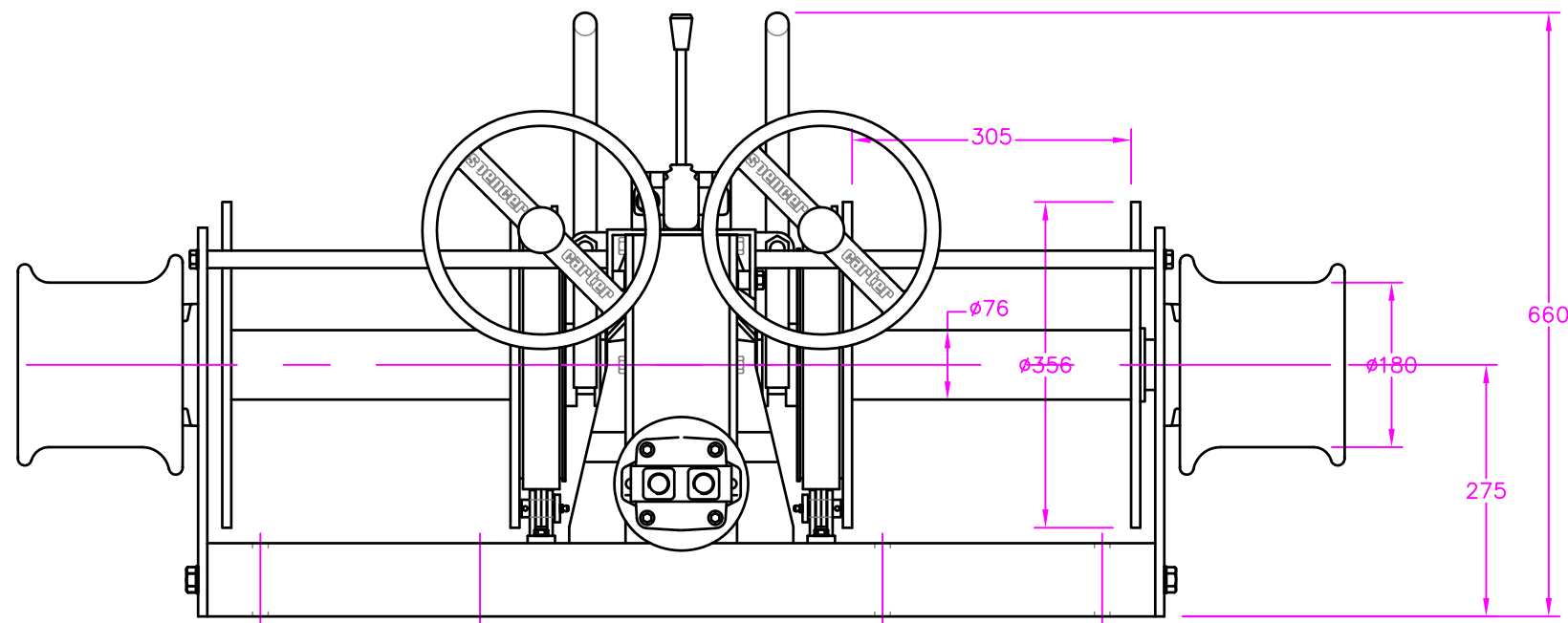

ALTERATIONS	DATE	ALTERATIONS	DATE
SCALE		1:8	
DRN.	M.J.S.	DATE	05:07:97



TITLE 1/2 TON TRAWL WINCH – TW1	
SPENCER CARTER LTD. FALMOUTH, CORNWALL, U.K.	DRG.NO. 623-437
TEL. (01326) 373423 FAX. (01326) 373571	