

8.0 HP HONDA POWER PACK

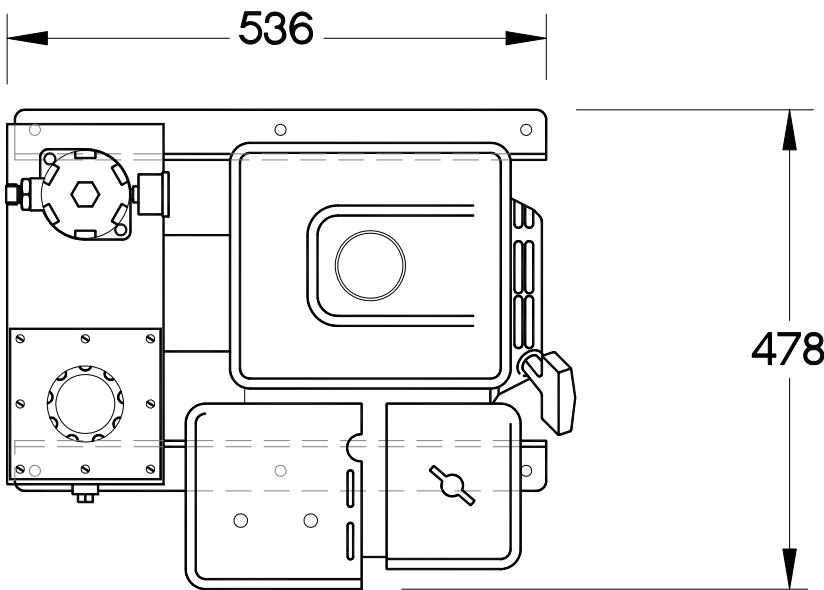

Honda petrol re-coil start engine on Hot dip galvanised mounting base. Stainless oil Reservoir.
Options electric start + 12v battery. Jabsco 12v clutched water pump.
Engines up to 13HP.
Diesel Engines available



Engine.....Honda GX240
 Max running speed.....3600 RPM
 Max Power.....8.0 HP
 Hydraulic Pump...Gear pump 7.0cc/Rev
 Max Flow rate.....25LPM @ 3500 RPM
 Max Pressure.....120 Bar
Continuous working output, at 3000 RPM
 Flow rate.....20 LPM
 Pressure.....105 Bar
 Reservoir Capacity.....11 Litre
 Dry Weight.....

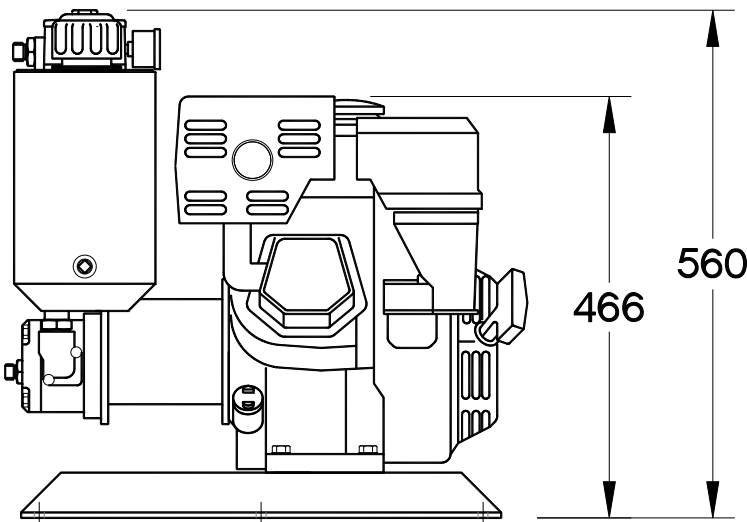

Spencer Carter Ltd
Tregonnig Industrial Estate,
Falmouth, Cornwall,
TR11 4SN
Tel: 01326 373423
Fax: 01326 373571
Email: Info@spencercarter.com
www.spencercarter.com