

5.5 HP HYDRAULIC POWER PACK

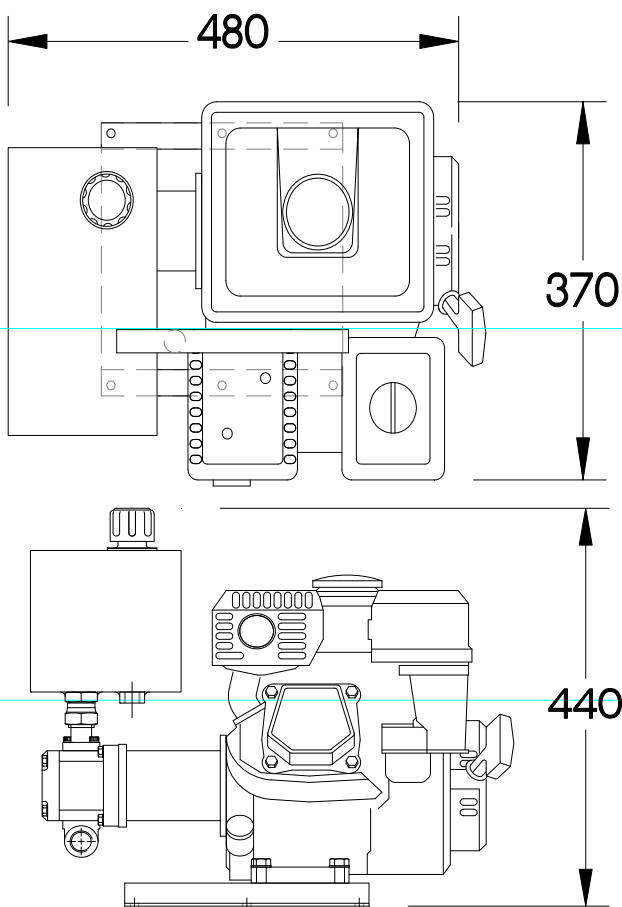

Honda re-coil start engine. On Hot Dip Galvanised mounting base. Stainless steel Oil reservoir.



**Engine.....Honda 5.5 HP
Max.power.....5.5 HP
Max.running speed.....3500 RPM
Hydraulic pump.....gear pump4.4 cc/rev
Max.pressure.....120 bar
Continuous working speed.....3000 RPM
Continuous flow rate.....13 LPM
Continuous working pressure.....100 bar
Reservoir capacity.....4.5 litre
Dry weight.....24KG**



**Spencer Carter Ltd
Tregonnigie Industrial Estate
Falmouth
Cornwall, TR11 4SN
Tel: 01326 373423
Fax: 01326 373571
Email: Info@spencercarter.com
www.spencercarter.com**