

INLET AND OUTLET PORT ADAPTERS CAN BE ROTATED THROUGH 90° DIRECTIONS.

PORT ADAPTERS WILL CHANGE SIDES IF THE PUMP IS SUPPLIED FOR CLOCKWISE ROTATION.

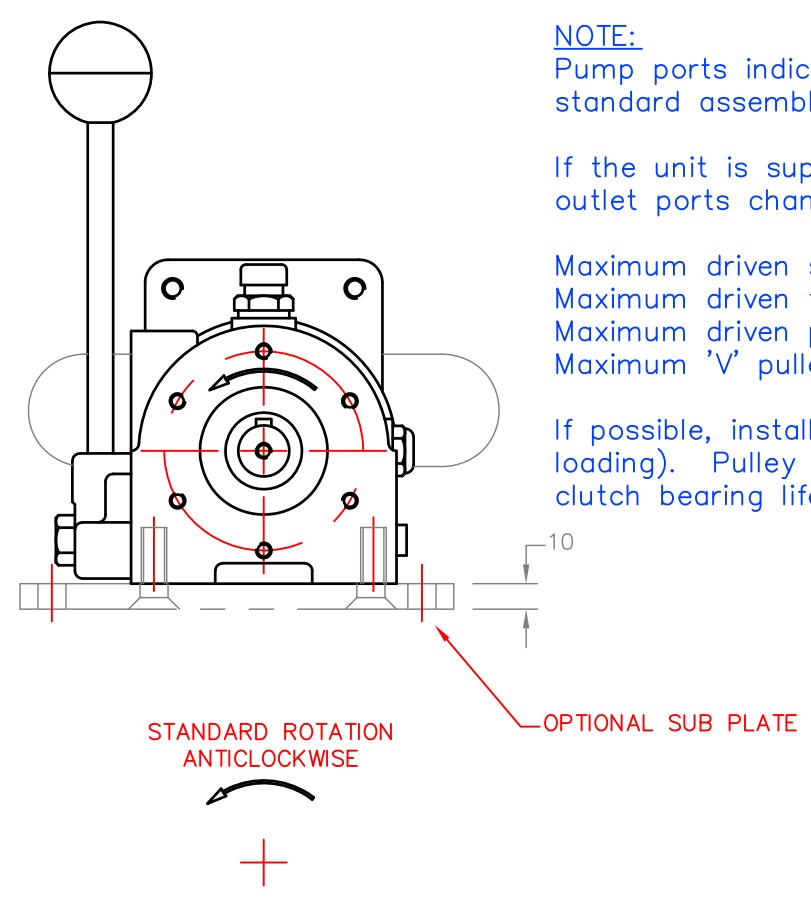
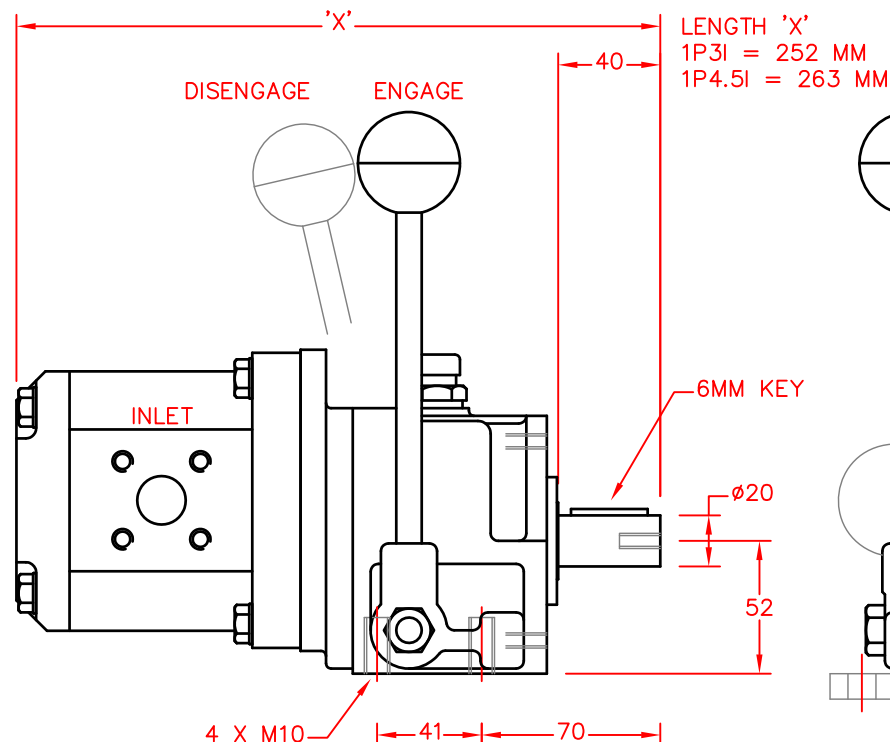
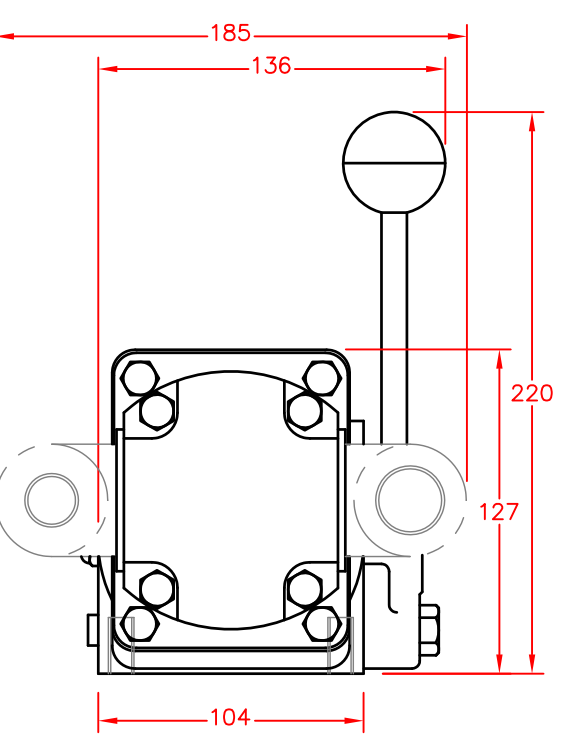

1P PUMP/CLUTCH UNIT.

There are two pump sizes offered as standard, both using the 1P 'ULTRA' fixed delivery gear pump.

MODEL 1P3I – 13 LPM at 1000 RPM. Max. pressure 200 bar.
MODEL 1P4.5I – 21 LPM at 1000 RPM. Max. pressure 200 bar.

Base mounting, and suitable for flexible coupling or vee belt drive.
 Morse cable control can be fitted for remote operation of clutch engagement and disengagement.

CLUTCH – Totally enclosed mechanical dog clutch running in an oil bath. no clutch adjustments are required. Maintenance is limited to checking the oil level, or changing the oil once every year.

HYDRAULIC PUMP – Heavy duty aluminium cased gear pump with adapter ports for inlet and pressure out couplings. No local maintenance of the pump is required since lubrication is provided by the system hydraulic oil.

Weight... Approx. 7.5 Kg.

NOTE:
 Pump ports indicated as inlet and outlet are correct for the standard assembly, with direction of rotation – anticlockwise.

If the unit is supplied for clockwise rotation, the inlet and outlet ports change sides.

Maximum driven speed _____ 2000 RPM.
 Maximum driven torque _____ 90 Nm.
 Maximum driven power _____ 25 HP.
 Maximum 'V' pulley side load _____ 140 Kg.

If possible, install as an inline flexible coupling drive (no side loading). Pulley drives and subsequent side loads will reduce clutch bearing life.

ALTERATIONS	DATE	ALTERATIONS	DATE			TITLE	
						1P PUMP/CLUTCH UNIT	
				SCALE		DRG.NO.	
				1:2		SPENCER CARTER LTD.	
				DRN. M.J.S.		FALMOUTH, CORNWALL, U.K.	
				DATE 23:04:98		TEL. (01326) 373423	
						FAX. (01326) 373571	
						623-229	